

MRQ300/350V06 Open-Convertible Installation Instructions

Congratulations on your purchase of the MiniRaQ™ Network wall mounted vertical rack system. This system is available in 4U, 6U, 8U and 10U projections allowing a maximum U space utilization of 10U to 16U when using the internal back plate flanges (A) and 4U of patch panel space (B). These flanges (A), welded internally on each side of the back plate are aligned with the mounting surface projections (side panels). This allows you the option to mount another 2U of equipment in a vertical orientation. This 2U can be combined with the vertical U spacing provided by the side panels to enable deployment of larger pieces of equipment. For instance, if you have 4U side panels and a device that is 6U, the device could still be installed in this MiniRaQ™ by using the additional 2U provided internal to the back plate. Please note that this 2U space may be encroached upon by any cabling that is attached to patch panels installed in the 4U space at the top of the back plate. The MiniRaQ™ is designed from heavy gauge steel and finished to last a lifetime. It is designed to hold up to 400 pounds when properly installed for your most demanding needs such as extended runtime battery back-up systems, low profile power distribution transformers, POE equipment and any other 17" rack mountable products.

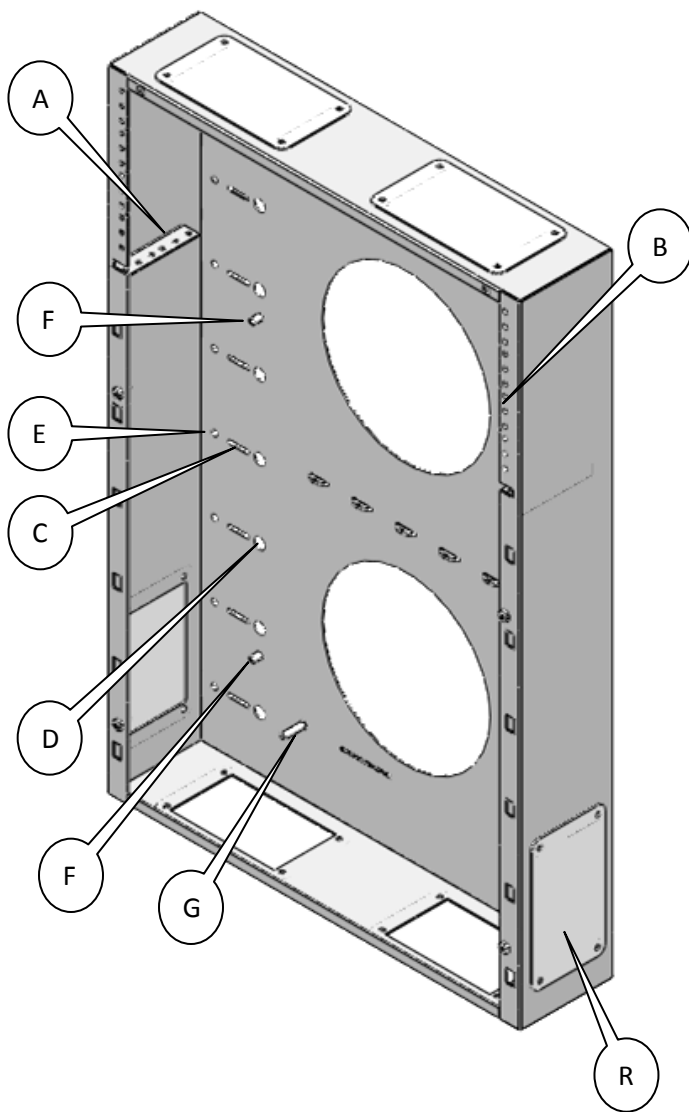

The MiniRaQ™ System can be mounted on a variety of vertical substrates including wooden framing studs 16" on center (C), solid or block concrete walls, and approved plywood used for NEC panel mounting.

Locate solid studs, 16" on center before marking top two locations for pilot holes. Drill .156" (for #10 coarse screws), in the slots (C) spaced nominally at 16" at the top and using the integrated level to locate proper mounting pattern. Tighten the first 2 screws when level then drill and install the remaining locations a minimum of 10 locations for full payload rating of 400LBS.

The same process should be used for installing to other approved surfaces and using the 1/2" clearance holes (D) for toggle bolts into cinder block or 3/4" plywood backed wall or fender washers and concrete tapping screws (3/16" X 2 - 1/4" minimum size recommended) or expansion bolts installations. There is also a hole pattern to attach the secure cabinet to a 2 Post Rack (E), in a situation where shared services may be deployed or clearances for deep components are not favorable.

MRQ300/350V06 Open-Convertible Installation Instructions

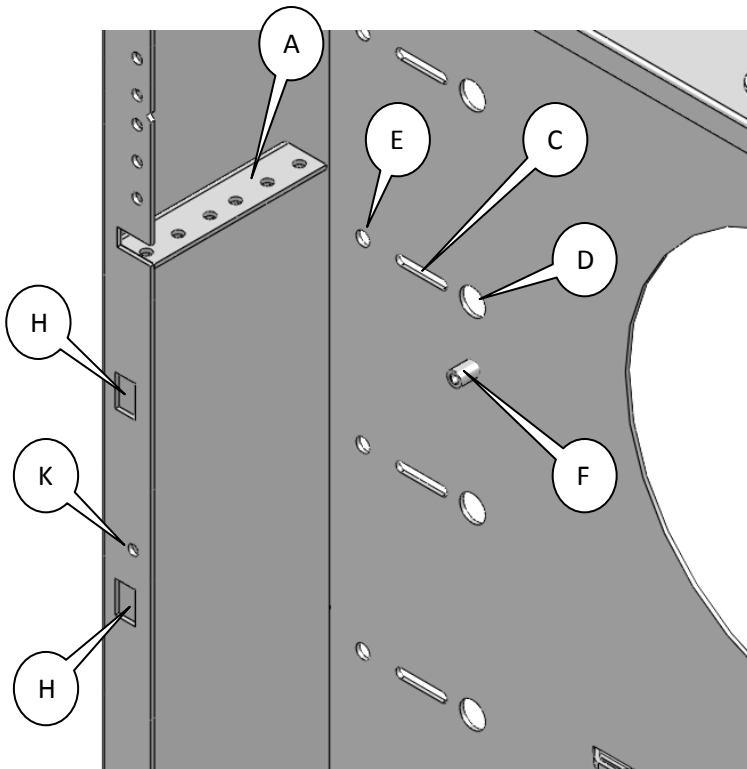

Be sure to follow hardware manufacturers recommended procedures.

Other features include optional 3/4" Plywood mounted within the secured space on the back plate. This option comes with pre drilled holes and flat head screws to mount to 4 stand offs (F) located on inside mounting surface. Also included on this surface is the integrated level to assist in true alignment of back plate during installation and a chassis grounding stud (G).

The back plate is equipped with 6 removable access panels (R) which can be used for routing solid or metal flex conduit or data and fiber in the most optimized placement for your configuration. Optional panels include brush strip assembly and RJ45 data pass through connector.

After ensuring the back plate has been properly and completely fastened to the wall per manufacturers' instructions, your equipment can now be installed and configured.

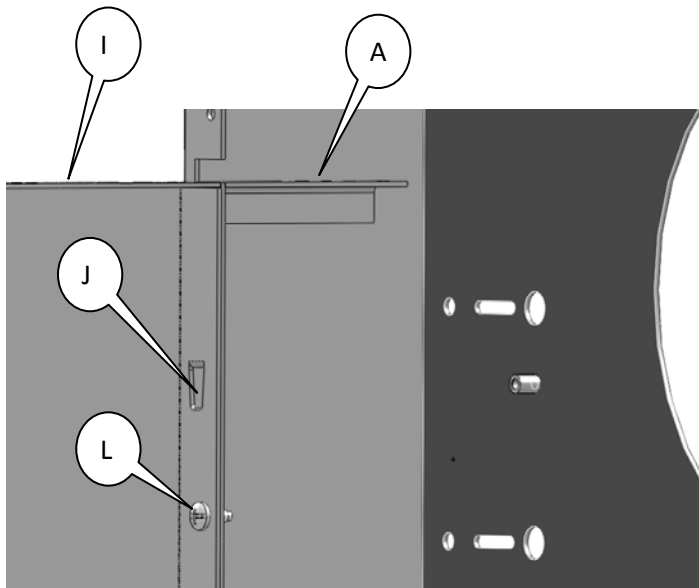

MRQ300/350V06 Open-Convertible Installation Instructions

BlackHawk Labs, LLC Limited Factory Warranty: The limited warranty provided by BlackHawk Labs, LLC (BHL) in this Statement of Limited Factory Warranty applies only to Products purchased for commercial or industrial use in the ordinary course of your business.

Terms of Warranty: BHL warrants its products to be free from defects in materials and workmanship for a period of five years (two years in Japan) from the date of purchase. Its obligation under this warranty is limited to repairing or replacing, at its sole discretion, any such defective products. This warranty does not apply to equipment that has been damaged by accident, negligence, or misapplication or has been altered or modified in any way. Repair or replacement of a defective product or part thereof does not extend the original warranty period. Any parts furnished under this warranty may be new or factory-reconditioned.

Non-transferable Warranty: This warranty applies only to the original purchaser who must have properly registered the product. Product may be registered at <http://www.bhpower.com/support>.

Exclusions: BHL shall not be liable under the warranty if its testing and examination disclose that the alleged defect in the product does not exist or was caused by end user's or any third person's misuse, negligence or improper installation. Further BHL shall not be liable under the warranty for unauthorized attempts to repair or modify inappropriate on-site operating conditions, corrosive atmosphere, installation, a change in location or operating use, exposure to the elements, Acts of God, fire, theft, or installation contrary to BHL recommendations or specifications or in any event if the BHL serial number has been altered, defaced, or removed, or any other cause beyond the range of the intended use.

THERE ARE NO WARRANTIES, EXPRESS OR IMPLIED, BY OPERATION OF LAW OR OTHERWISE, OF PRODUCTS SOLD, SERVICED OR FURNISHED UNDER THIS AGREEMENT OR IN CONNECTION HEREWITH. BHL DISCLAIMS ALL IMPLIED WARRANTIES OF MERCHANTABILITY, SATISFACTION AND FITNESS FOR A PARTICULAR PURPOSE. BHL EXPRESS WARRANTIES WILL NOT BE ENLARGED, DIMINISHED, OR AFFECTED BY AND NO OBLIGATION OR LIABILITY WILL ARISE OUT OF, BHL RENDERING OF TECHNICAL OR OTHER ADVICE OR SERVICE IN CONNECTION WITH THE PRODUCTS. THE FOREGOING WARRANTIES AND REMEDIES ARE EXCLUSIVE AND IN LIEU OF ALL OTHER WARRANTIES AND REMEDIES. THE WARRANTIES SET FORTH ABOVE CONSTITUTE BHL SOLE LIABILITY AND PURCHASER'S EXCLUSIVE REMEDY FOR ANY BREACH OF SUCH WARRANTIES. BHL WARRANTIES RUN ONLY TO PURCHASER AND ARE NOT EXTENDED TO ANY THIRD PARTIES.

BHL WILL IN NO WAY BE LIABLE FOR ANY FORM OF INDIRECT, SPECIAL, CONSEQUENTIAL OR PUNITIVE DAMAGES, ARISING OUT OF THE USE, SERVICE OR INSTALLATION, OF THE PRODUCTS, WHETHER SUCH DAMAGES ARISE IN CONTRACT OR TORT, IRRESPECTIVE OF FAULT, NEGLIGENCE OR STRICT LIABILITY OR WHETHER BHL HAS BEEN ADVISED IN ADVANCE OF THE POSSIBLY OF SUCH DAMAGES. SPECIFICALLY, BHL IS NOT LIABLE FOR ANY COSTS, SUCH AS LOST PROFITS OR REVENUE, LOSS OF EQUIPMENT, LOSS OF USE OF EQUIPMENT, LOSS OF SOFTWARE, LOSS OF DATA, COSTS OF SUBSTITUTES, CLAIMS BY THIRD PARTIES, OR OTHERWISE. NO SALESMAN, EMPLOYEE OR AGENT OF BHL IS AUTHORIZED TO ADD TO OR VARY THE TERMS OF THIS WARRANTY: WARRANTY TERMS MAY BE MODIFIED, IF AT ALL, ONLY IN WRITING SIGNED BY A BHL OFFICER AND LEGAL DEPARTMENT.

MRQ300/350V06 Open-Convertible Installation Instructions

Warranty Claims: Customers with warranty claims issues may access the BHL worldwide customer support network by visiting <http://www.bhlpower.com/support>.

BHL Customer Support: Customer support for this or any other BHL product is available at no charge in any of the following ways:

- Visit <http://www.MiniraQ.com> Web site to access documents and to submit customer support requests.
- www.bhlpower.com (Corporate Headquarters) Customer Support Line: (1)(877)427-2522 (toll free)

BHL headquarters USA BlackHawk Labs, LLC 4 Owens Court Hampstead, NH 03841

Please recycle packaging materials

Entire contents copyright 2007, 2010 BlackHawk Labs, LLC. All rights reserved.

Reproduction in whole or in part without permission is prohibited. BHL, the BHL logo, and MiniRaQ are trademarks of BlackHawk Labs, LLC. All other trademarks, product names, and corporate names are the property of their respective owners and are used for informational purposes only.

