

ITEM #	PART #	DESCRIPTION	QTY.
1	20-255	BACK PLATE	1
2	20-252	LEFT SIDE PANEL	1
3	20-251	RIGHT SIDE PANEL	1

4U FOR EQUIPMENT MOUNTED
VERTICALLY ON BACKPLATE

2U FOR EQUIPMENT MOUNTED
VERTICALLY INSIDE OF BACKPLATE

8U FOR EQUIPMENT MOUNTED
VERTICALLY ON SIDE PANELS

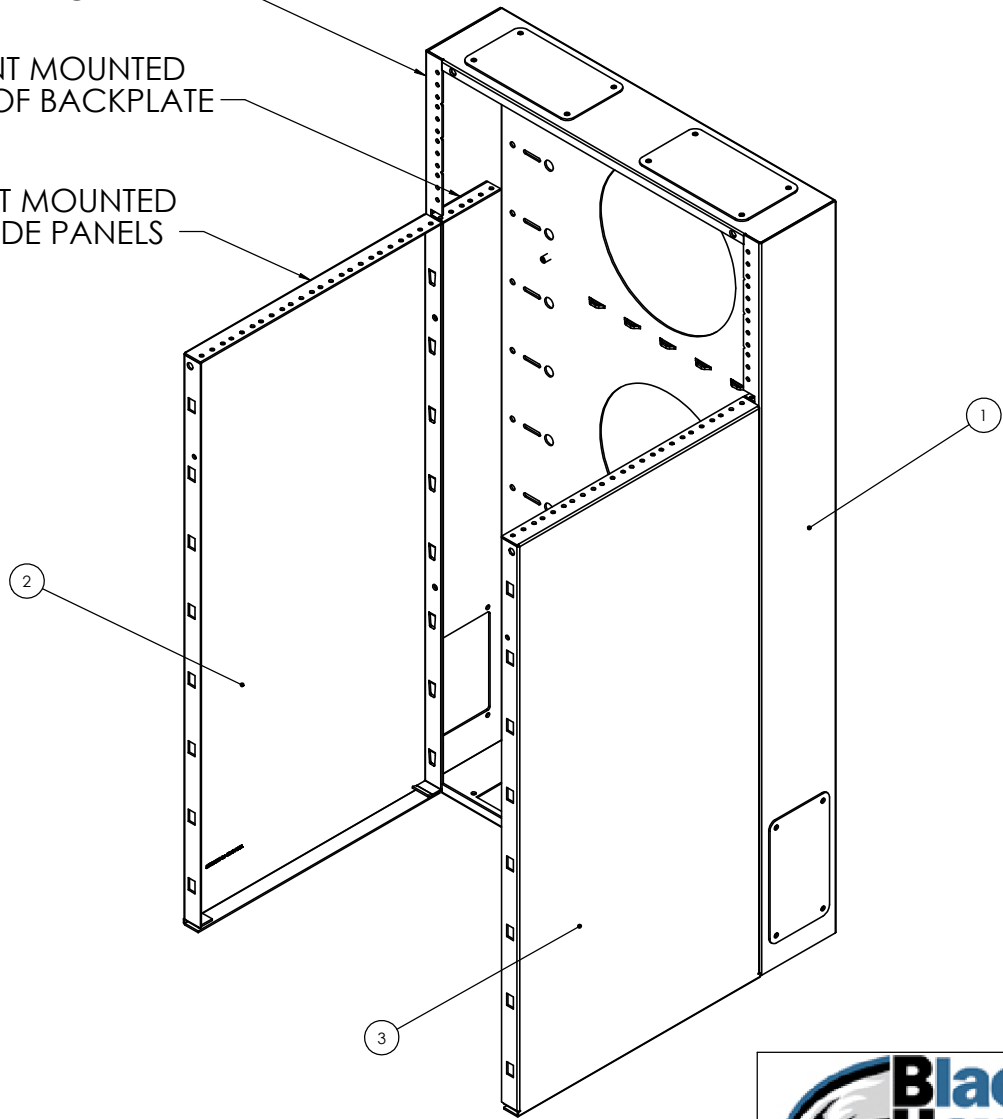

NOTES:

1. INSTALLATION MUST COMPLY WITH NATIONAL AND LOCAL ELECTRICAL REGULATIONS.
2. ALL DIMENSIONS ARE IN INCHES.
3. NET WEIGHT OF UNIT IS 44 LBS.
4. CABLE ENTRY IS TOP, BOTTOM, AND SIDES OF UNIT.
5. EQUIPMENT MOUNTING IS 12-24 TAPPED IN EIA PATTERN.
6. CAPACITY IS 400 LBS. WHEN MOUNTED AS RECOMMENDED.
7. CONSTRUCTION IS 14AWG C.R. STEEL WITH BLACK POWDER COAT FINISH.



PROPRIETARY AND CONFIDENTIAL
THE INFORMATION CONTAINED IN THIS DRAWING IS THE SOLE PROPERTY OF BLACKHAWKLABS. ANY REPRODUCTION IN PART OR AS A WHOLE WITHOUT THE WRITTEN PERMISSION OF BLACKHAWKLABS IS PROHIBITED.

COMMENTS:			
MRQ300V14 Sheet 1/2			
TITLE:			
MiniRaQ Standard			
SIZE	DWG. NO.	DATE	REV
C	90-088	3-22-11	2
SCALE: 1:8		WEIGHT: 44 lbs	SHEET 1 OF 2

TOP

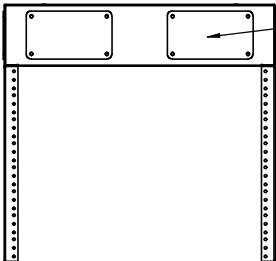

TWO PLATES COVERING 3"x5" CABLE ACCESS OR ACCESSORY HOLES

FRONT

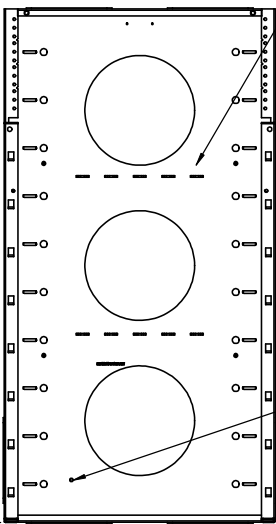

37.44

BOTTOM

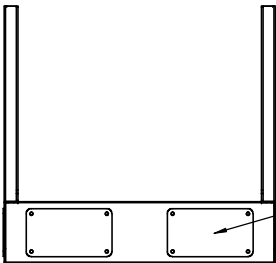

TWO PLATES COVERING 3"x5" CABLE ACCESS OR ACCESSORY HOLES

10 RAISED BRIDGE LANCES FOR CABLE MANAGEMENT (INTERNAL)

RIGHT

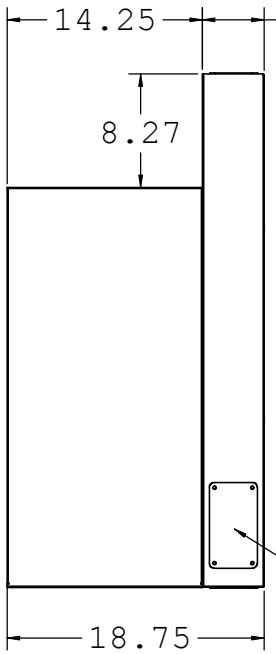

3.50 PATTERNED

14.00 SQUARE FOR PLYWOOD

ONE PLATE EACH SIDE COVERING 3"x5" CABLE ACCESS OR ACCESSORY HOLES

REAR

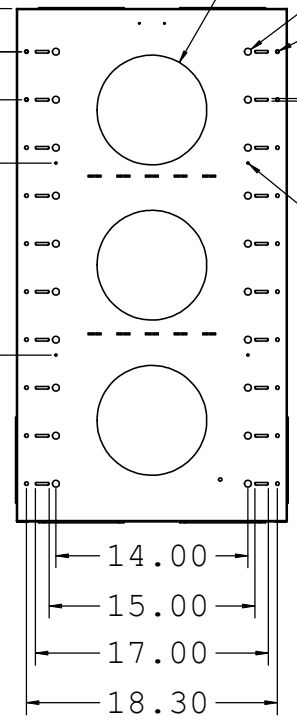

Ø 8.00

Ø .50

Ø .27

.19

Ø .28 FOR PLYWOOD PEMS (INTERNAL)

14.00

15.00

17.00

18.30

- NOTES:**
1. INSTALLATION MUST COMPLY WITH NATIONAL AND LOCAL ELECTRICAL REGULATIONS.
 2. ALL DIMENSIONS ARE IN INCHES.



Black Hawk Labs
 PROPRIETARY AND CONFIDENTIAL
 THE INFORMATION CONTAINED IN THIS DRAWING IS THE SOLE PROPERTY OF BLACKHAWKLABS. ANY REPRODUCTION IN PART OR AS A WHOLE WITHOUT THE WRITTEN PERMISSION OF BLACKHAWKLABS IS PROHIBITED.

COMMENTS:			
MRQ300V14 Sheet 2/2			
TITLE:			
MiniRaQ Standard			
SIZE	DWG. NO.	DATE	REV
C	90-088	3-22-11	2
		DRAWN BY ML	
SCALE: 1:8		WEIGHT: 44 lbs	
SHEET 2 OF 2			